

ML-1

Polarization Stabilized Laser Operator's Manual

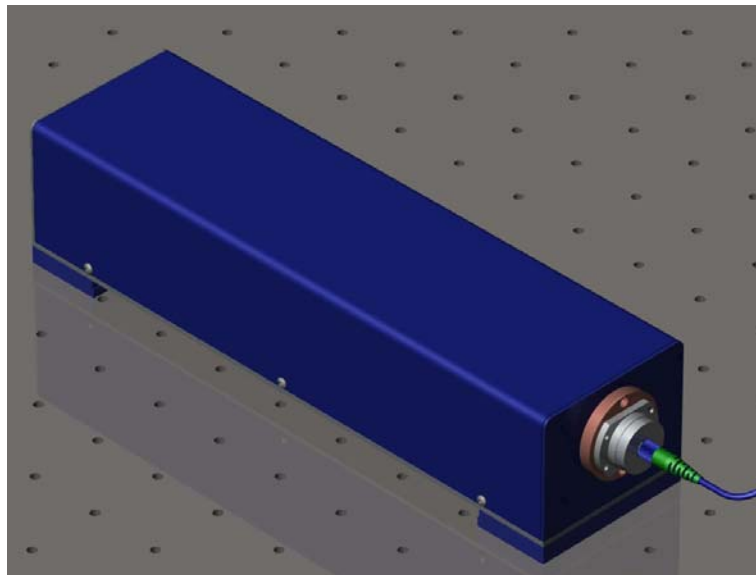

*© Copyright 2011 Micro-g LaCoste All Rights Reserved
Reproduction, adaptation, or translation without prior written permission is
prohibited, except as allowed under the copyright laws.*

*Publication Number 115-067-001A
Version 1.01, 10 March 2011*

*Applicable Products
Micro-g LaCoste FGL/FG5L Absolute Gravimeter*

*Disclaimer
The information contained in this document is subject to change without notice.
Micro-g LaCoste makes no warranty of any kind. Micro-g LaCoste shall not be
liable for errors contained herein or for incidental or consequential damages in
connection with the furnishing, performance, or use of this material.*

Contact
Micro-g LaCoste
1401 Horizon Avenue
Lafayette, Colorado 80026
USA

Tel: (303) 828-3499
Fax: (303) 828-3288
E-Mail: info@microglacoste.com
Website: www.microglacoste.com

Table of Contents

Section	Page
1. Introduction.....	1-1
Product Description	1-1
Physical Specifications.....	1-2
2. Unpacking And Safety Precautions	2-1
Unpacking	2-1
Laser Head	2-1
Laser Controller	2-2
Laser Safety Precautions	2-2
Environmental Considerations	2-2
Magnetic Fields	2-3
Shock Vibration.....	2-3
Optical Feedback	2-3
Dust, Dirt And Fingerprints	2-3
Temperature.....	2-3
3. Quick Laser Setup	3-1
4. Principles Of Operation.....	4-1
5. Laser Controller: Front Panel	5-1
Mode Select Switch.....	5-1
Laser Locks	5-1
Remote Switch.....	5-2
Power	5-2

6. Laser Controller: Back Panel	6-1
Power	6-1
BNC	6-1
Remote Control	6-2
7. Setting Up The Temperature Control.....	7-1

List of Figures

Figure 1-1 ML-1 Frequency Stablized Reference Laser	1-1
Figure 2-1 ML-1 Laser Controller	2-1
Figure 4-1 The AL-1 Laser Head	4-1
Figure 4-2 Lock Points	4-2
Figure 4-3 Laser Gain Profile.....	4-3
Figure 5-1 Laser Controller: Front Panel	5-1
Figure 6-1 Laser Controller: Back Panel Connections	6-1



1. INTRODUCTION

Product Description	1-1
Physical Specifications	1-2

This manual has been carefully prepared to provide the information needed to operate the ML-1 He-Ne Laser and to understand its design principles. The ML-1 requires no operator-level maintenance for normal operations. No service procedures should be attempted due to high voltages inside the laser head and controller.



Figure 1-1 ML-1 Frequency Stabilized Reference Laser

Product Description

The ML-1 is a new, small, low cost laboratory He-Ne laser. The ML-1 provides a linear-polarized, frequency-stabilized, coherent, light source of continuous wave (CW) visible (red) laser light with a nominal output power of 1 mWatt.

The ML-1 laser is ideal for laboratory measurements, spectroscopy, interferometry, and other sensitive distance measurements. The frequency of the ML-1 laser is stabilized and calibrated at the factory to provide an ideal light source wherever a visible calibrated light source is needed.

Physical Specifications

Laser Head:

Dimensions	3 ½ " × 2 ¾" × 13 "
Weight	3 lbs.
Beam Height	2" from bottom of base

Laser Controller:

Dimensions	10 ½" × 8 ½ " × 1 ¾"
Weight	3.5 lbs
Maximum Input Power:	35Watt (300mA @ 115VAC)
Input Voltage:	100-240 VAC
Nominal Output Laser Power:	1 mWatt



2. UNPACKING AND SAFETY PRECAUTIONS

Unpacking.....	2-1
Laser Head.....	2-1
Laser Controller	2-2
Laser Safety Precautions.....	2-2
Environmental Considerations.....	2-2
Magnetic Fields	2-3
Shock Vibration	2-3
Optical Feedback.....	2-3
Dust, Dirt And Fingerprints	2-3
Temperature	2-3

The ML-1 consists of a laser head connected to a one rack-unit half-width electronics box called the laser controller. These are shipped together in the same box but are wrapped separately. Open the shipping box carefully and unpack the laser head and laser controller.

The shipping box contains the following components:

- Laser Head
- Laser Controller (including keys for high voltage)
- Grey Control Cable
- Black High Voltage Cable (SHV ends)
- AC power cord
- Operator's Manual
- Calibration sheets (Frequency calibration and Allan Variance plot)

Unpacking

Laser Head

First unpack the laser head from its shipping box. Then find the three cables.

- The gray cable carries signals between the laser head and the controller.
- The black cable carries high voltage (HV) from the laser controller to the laser tube inside the laser head.
- The third cable is a standard AC power cord.

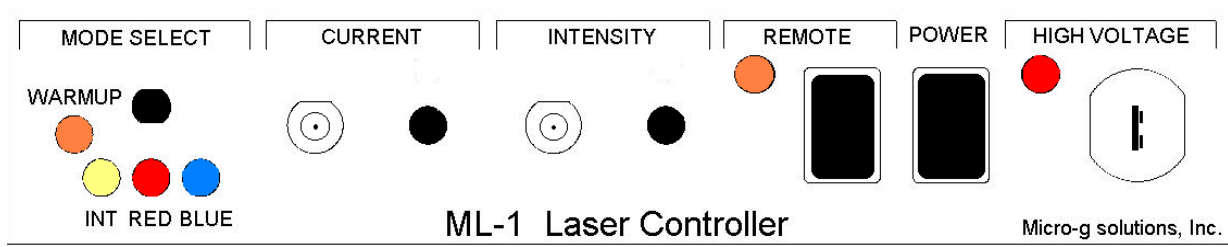

Figure 2-1 ML-1 Laser Controller

Laser Controller

Next, unpack the laser controller.

- Connect the two laser head cables between the controller and the laser head. The laser controller has a key switch (see right hand side of Figure 2-1).
- Verify that the key is present and inserted into the key switch.
- Unpack the AC power cord and attach it to the back of the laser controller.

Laser Safety Precautions

IMPORTANT All personnel who will operate or are in the vicinity of the ML-1 while it is in use must be made aware of the potential hazards of a laser.

The following safety precautions should be strictly adhered to:

- Never look directly into the laser beam.
- Controlled-access areas are recommended for laser operation.
 - Limit access to these areas to persons who have been instructed in the safe operation of lasers.
- Post warning signs in prominent locations near the laser area.
- Provide enclosed paths for laser beams when possible.
- Set up experiments so the laser beam is NOT at eye level.
- Especially avoid having laser beams shining in the room near eye level (including that of small children or animals).
- Block all unused beams from both the front and rear of the laser so that they will not be accidentally directed into anyone's eyes.
 - The main laser power is emitted by the front of the laser but a small amount of laser light is emitted from the rear of the laser tube as well.
 - This light can be used or blocked.
 - Any light that is blocked should be done using a mat-black surface at an angle to the beam so that any reflected light does not go back into the laser

Environmental Considerations

The ML-1 is ruggedly constructed but is sensitive to several types of disturbances which can degrade its stability.

Magnetic Fields

Magnetic Fields of a few Gauss can seriously perturb the laser. They can cause a mode switch at the top of the Doppler profile, making it impossible to lock to one side of the laser line. A magnetic field of this magnitude can also produce a frequency shift of a few MHz. Use common-sense precautions such as avoiding magnetic clamps in the vicinity of the laser to avoid any potential problem.

Shock Vibration

Shock and Vibration can misalign the ML-1's optics. Treat the ML-1 with reasonable care.

Optical Feedback

Optical Feedback of laser light reflected or scattered back into the output aperture can seriously degrade the stability of the ML-1. Use of a Faraday isolator, acousto-optic modulator or a quarter-wave plate and polarizer is recommended.

Dust, Dirt And Fingerprints

Dust, dirt, and fingerprints on the laser optics can lead to unreliable operation due to scattering and feedback. The laser head must be kept in a clean environment.

Temperature

Temperature fluctuations of a few °C can cause the frequency stability of the laser to drift by hundreds of MHz. While the laser head is designed to stabilize the internal laser temperature (Refer to [Section 7](#)), a locally controlled environment will produce better results.



3. QUICK LASER SETUP

ML-1 Laser setup procedures:

1. Place the laser head on a stable surface.
 - Excessive vibration and/or loud noises will introduce acoustic noise into the laser lock and can make the lock less stable.
2. Attach the gray control cable and the black high voltage cable (SHV ends) between the laser head and the controller.
3. Plug the AC cord into the controller and into the main power.
4. Turn on the AC POWER switch.
5. Observing the above-mentioned safety precautions, turn the high voltage key switch clockwise to engage the high voltage.
6. Check to verify that the controller is in local front panel operation.

NOTE

The REMOTE LED should not be lit.

7. The WARMUP LED on the laser head should be ON (and not blinking).
 - For normal laboratory conditions, check that the SET TEMPERATURE voltage is approximately 0.4 V (indicating a desired internal temperature of 40 °C, refer to [Section 7, "Setting Up The Temperature Control"](#))
8. Turn the MODE switch to the WARMUP position.
9. Set the heater current to about 0.3V (1mV = 1mA heater current).
 - Monitor and/or set this using a voltmeter on the front panel BNC.
10. Allow the laser to warm up at least ½ hour before locking the laser.
 - The WARMUP LED on the laser head should now be blinking.
11. Lock the laser by turning the MODE switch to either RED or BLUE mode for frequency stabilization.
 - The laser can also be locked to stabilize the output power by turning the MODE switch to INT (INTensity).
12. Try to minimize all sources of optical feedback back into the laser.

NOTE

Optical feedback can destabilize the locking electronics. It is recommended to use either a Faraday isolator or an Acousto-Optic Modulator to prevent optical feedback.

13. Block all unused reflected beams from both the front and rear of the laser so that they will not be accidentally directed into anyone's eyes.
- Especially avoid having laser beams shining in the room near eye level (including that of small children or animals).
 - The main laser power is emitted by the front of the laser but a small amount of laser light is emitted from the rear of the laser tube as well. This light can be used or blocked.
 - Any light that is blocked should be done using a mat-black surface at an angle to the beam so that any reflected light does not go back into the laser.



4. PRINCIPLES OF OPERATION

The Micro-G LaCoste' ML-1 is a versatile and robust frequency-stabilized He-Ne laser which combines ease of use with advanced control features to fill many laboratory and field applications. It consists of a compact laser head and a control unit housing the laser electronics. It is designed to operate as a stand-alone unit or in conjunction with a computer or other remote controller in an integrated system (e.g. a Micro-g LaCoste FG5/FGL Gravimeter). When operated in the frequency-stabilized mode, it provides a single frequency, linearly-polarized output beam with 2×10^{-9} fractional frequency stability (over 24 hours) and 1 mW minimum output power. The intensity-stabilized mode generates an output beam with increased output power stability (0.1%) at the expense of some frequency stability for use in applications where the former is more important.

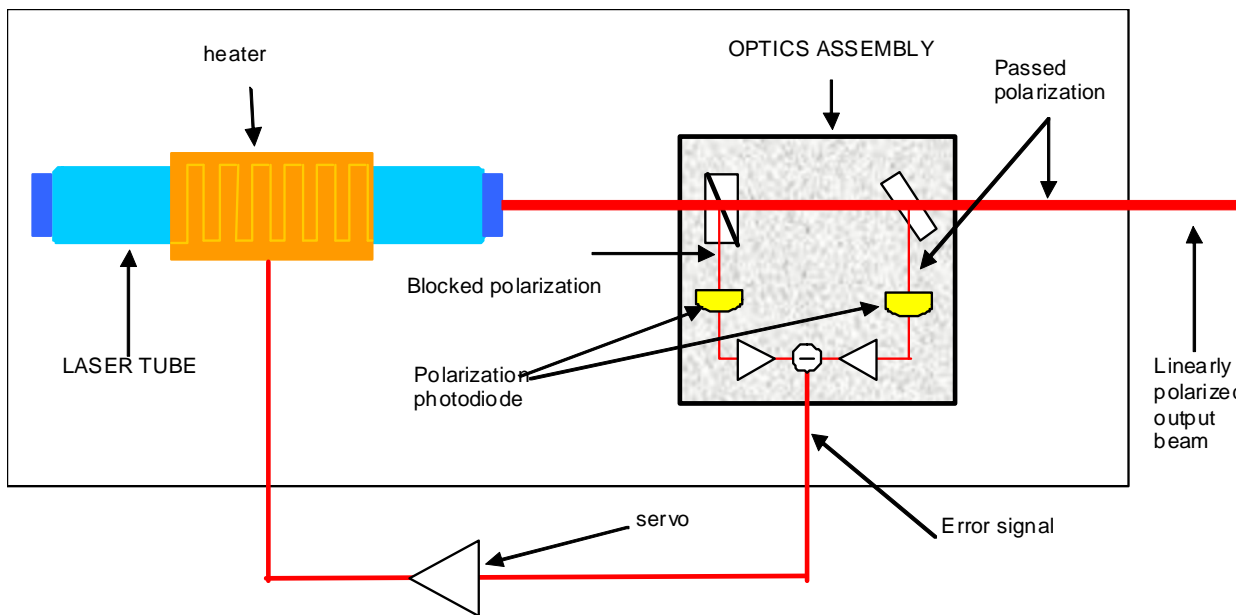

Figure 4-1 The AL-1 Laser Head

The Micro-g LaCoste ML-1 is a “polarization-stabilized” He-Ne laser. Its frequency stability is obtained by balancing the intensities of two TM00 modes in the laser tube. These two modes have orthogonal linear polarizations, allowing them to be separately detected by independent photo detectors using polarizing optics. The length of the tube can be adjusted by changing the temperature using the heater. This variation in length affects the intensities of the blocked and passed polarizations which alternately vary from a minimum to a maximum level as seen in Figure 4-2. The difference (blocked-passed) signed is used to lock the laser cavity leading to a reduction of the free-running instability of the laser from 1-2 part in 10^6 to approximately a part in 10^{-8} for long time scales.

For more information on polarization stabilized lasers, see Applied Optics, Vol 27, Issue 7, pp. 1285-1289 (1988), T. M. Niebauer, J. E. Faller, H. M. Goodwin, J. L. Hall, R. L. Barger, “Frequency Stability Measurements on Polarization-Stabilized He-Ne Lasers.”

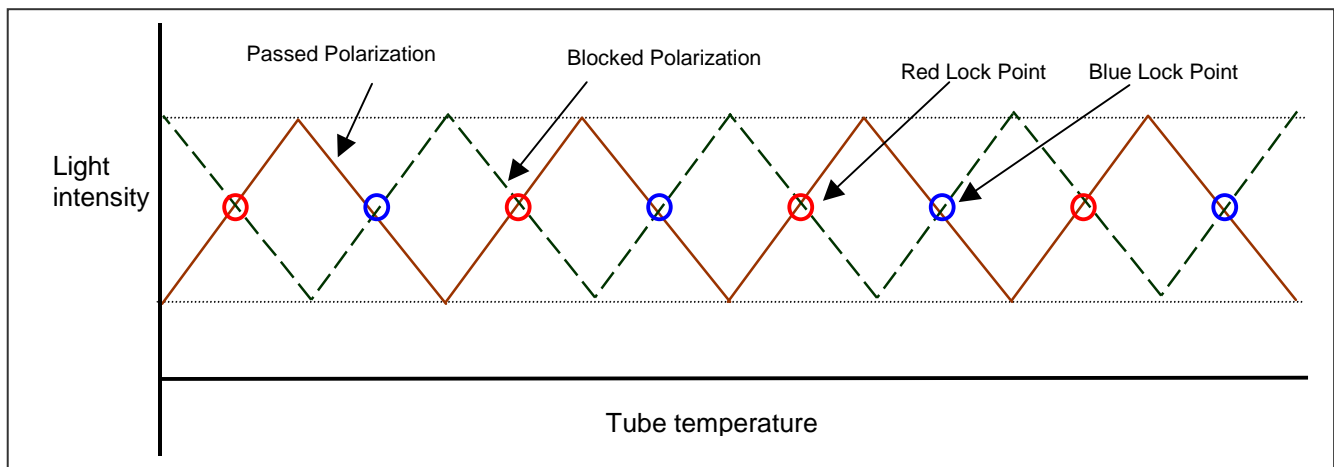

Figure 4-2 Lock Points

There are two possible lock points denoted in Figure 4-3 as "red" and "blue" mode. These two modes correspond to lock points on either side of the center of the laser gain profiles shown in Figure 4-3.

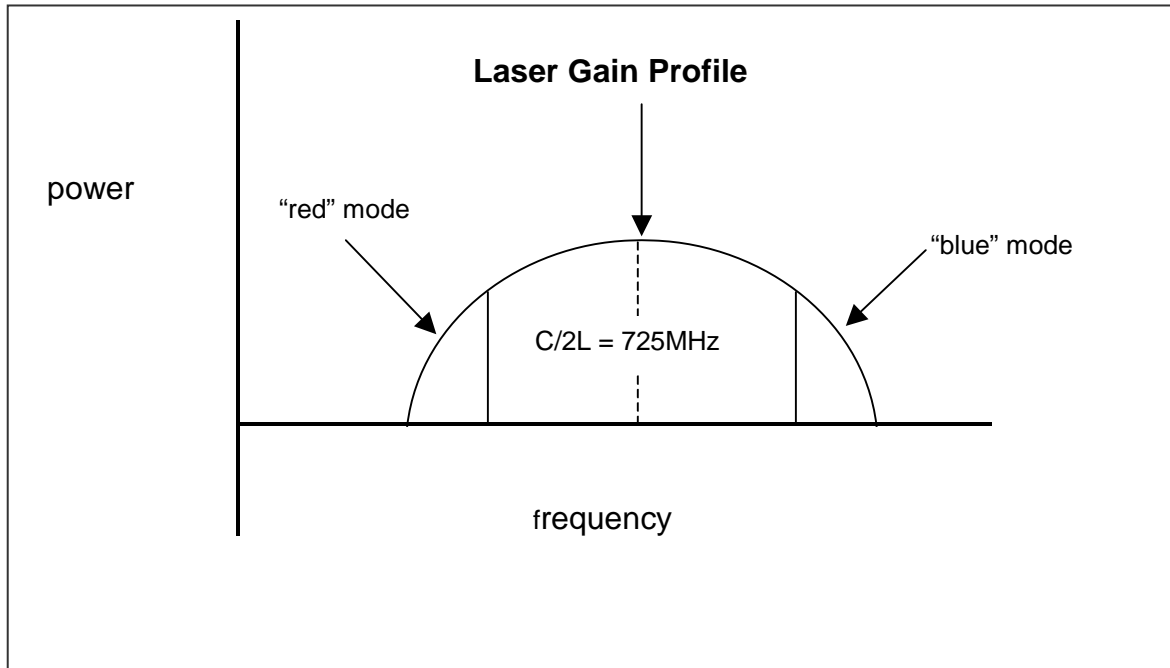

Figure 4-3 Laser Gain Profile



5. LASER CONTROLLER: FRONT PANEL

Mode Select Switch	5-1
Laser Locks	5-1
Remote Switch	5-2
Power.....	5-2

The Front Panel (see Figure 5-1) provides an interface to choose the operational mode, turn the unit on, and monitor several important voltages.

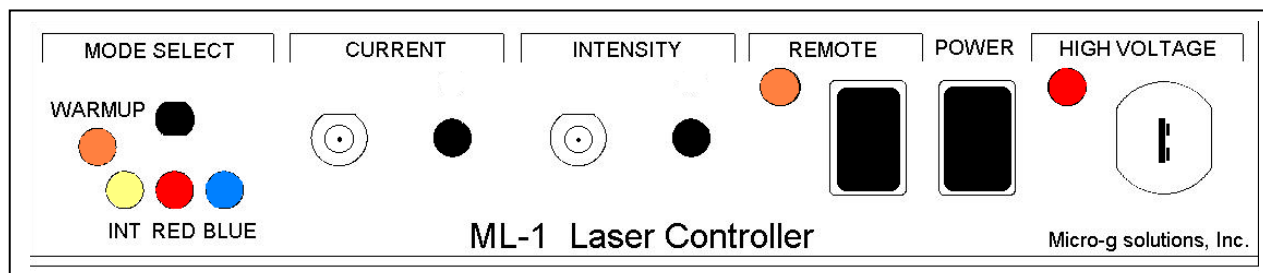

Figure 5-1 Laser Controller: Front Panel

Mode Select Switch

The **Mode Select** switch allows the operator to select between the operational modes of the laser: **WARMUP**, **INT**, **RED**, **BLUE** when the unit is in local operation (not in REMOTE operation). The unit should be set to the **WARMUP** mode when it is first turned on for at least ½ hour before locking the laser. During the warm up phase the nominal **CURRENT** should be set to about 300mV as read on the front panel **CURRENT** BNC connection. The current should be read with a standard voltmeter and set with the **CURRENT** knob.

Laser Locks

Once the laser is warmed up, the laser can be locked to one of three modes:

- RED Lock
- BLUE Lock
- INTENSITY Lock.

In either **RED** or **BLUE** side-lock, the laser frequency is stabilized. A laser calibration is available from the factory for the RED and BLUE side-locks. The two frequencies of RED and BLUE differ by about 700MHz and are both quite stable in frequency. However the average of the two frequencies is even more stable than either side lock alone. Therefore measurements should be taken with both the RED and BLUE side locks and then averaged to achieve the highest precision.

The laser can also be locked to stabilize the output power (intensity) of the laser. The output intensity can be varied using the **INTENSITY** knob on the front panel. It is advisable to check the intensity with a power meter while the front panel knob is rotated until the desired intensity is achieved. In the intensity stabilized mode the frequency is not controlled and in fact varies as the output intensity is varied. The INTENSITY BNC provides an output voltage proportional to the output intensity. This voltage is available for the user on the front panel.

Remote Switch

The **REMOTE** switch toggles the laser between front panel operation and remote operation.

When the laser is toggled to **REMOTE**, the LED lights is ON, indicating that the laser lock condition is being specified from the rear **REMOTE** connection.

When the laser is in **REMOTE**, the front panel mode switch, current knob, and intensity knob functions are disabled.

IMPORTANT

It is important to leave the laser in front panel or manual operation (not in REMOTE operation) when warming up the laser.

The mode switch will work only when the REMOTE switch is toggled to the off position.

Power

The laser is turned on using two switches:

- **POWER**
 - The **POWER** switch turns AC POWER on and provides DC voltages for the laser head and optics.
- **HIGH VOLTAGE**.
 - The **HIGH VOLTAGE** key switch must be turned to power up the laser tube.
 - This key switch will only work if the **POWER** switch has been turned on first.
 - Both the **POWER** and **HIGH VOLTAGE** key switch must be turned on for the laser to function properly.

It takes approximately three seconds for the laser light to come out of the laser once the key switch has been turned.

WARNING

DO NOT LOOK INTO THE END OF THE LASER HEAD. The laser light is powerful enough to cause damage to the retina and other parts of the eye.

Also beware that the laser light that is emitted from either end of the laser head can be inadvertently reflected into the user's eyes or other peoples' eyes.

Be very careful to block any unwanted reflections so others do not accidentally encounter them in the room.



6. LASER CONTROLLER: BACK PANEL

Power.....	6-1
BNC	6-1
Remote Control	6-2

The Back Panel of the Electronics Controller provides connections to the AC power as well as connections for the two cables coming from the laser head. There are also three test BNC connections that are not used in normal operations.

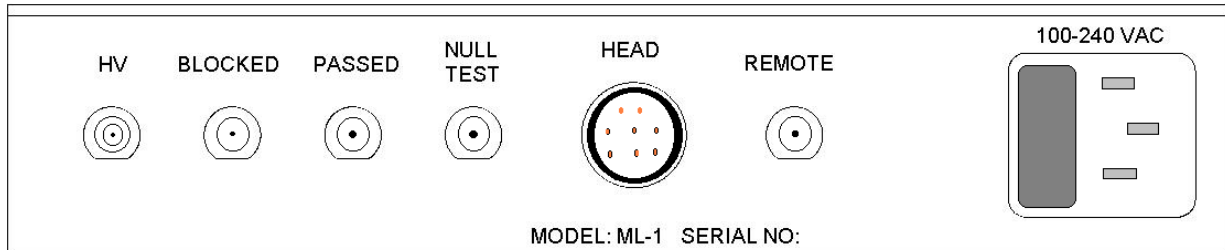

Figure 6-1 Laser Controller: Back Panel Connections

Power

The AC POWER is supplied to the laser using the universal AC power input module and can accept any AC voltage from 100-240 VAC 50-60Hz. The two laser head cables are:

- A gray signal cable with a 9 pin AMP connector.
- A black SHV cable that carries high voltage (HV) to the laser tube.

These should be connected to HV and HEAD connectors shown in Figure 6-1.

BNC

The three test BNC output connections labeled **BLOCKED**, **PASSED**, and **NULL TEST** are only used for test purposes and are not used in normal operation.

The **BLOCKED** and **PASSED** BNC outputs give the user access to the intensity of the two internal laser modes that are used to stabilize the laser.

The **NULL TEST** signal is another test voltage that shows the error signal used to stabilize the laser. The **NULL TEST** is nominally zero (AC variation of < 50mV) when the laser is operating properly. This BNC output can be used to determine if the laser is locking properly. It can also be used to determine if there is too much optical feedback into the laser that can destabilize the circuit.

Remote Control

The ML-1 laser provides a means for the remote automatic control by a computer using the **REMOTE** connector on the rear panel. The **REMOTE** audio jack provides a logical TTL input that can be used to automatically switch the laser between **WARM-UP**, **INTENSITY**, **RED** and **BLUE** side-locks.

A truth table shown in Table 6-1 indicates the logical remote selection. The **REMOTE** switch, on the front panel, has been selected. The REMOTE LED will be lit in this case. When using the laser in REMOTE mode it is still important to warm the laser for at least ½ hour before laser is locked to INTENSITY, RED or BLUE.

Table 6-1 Truth Table For Remote Selection

Control Bit 1	Control Bit 2	Mode
0	0	Current
0	1	Intensity
1	0	Blue
1	1	Red



7. SETTING UP THE TEMPERATURE CONTROL

The ML-1 laser tube is located in a thermally stabilized box to help maintain the frequency stability. The back of the ML-1 thermal control box is shown below. There are six points of interest:

SHV connection	The high voltage (HV) cable from the control box attaches here.
Control Cable Connection	The 9-pin control cable from the control box attaches here
Warmup LED	As the housing heater is activated the WARMUP LED will light. Thermal equilibrium is achieved when the light starts to blink. The LED is connected to the heater current – blinking indicates the heater current is cycling.
Current Laser Temperature	Current Laser Temperature BNC readout. This voltage provides the current temperature of the laser housing (0.01V/°C). For example, the nominal temperature of 40 °C would read 0.4 V.
Set Temperature	Control Temperature Set Value BNC readout. This connector displays the current setting of the housing control temperature (0.01V/°C). To determine what this value should be, do the following: <ul style="list-style-type: none"> • Set the value to something lower than the current housing temperature so that the heat control does not turn on (LED remains dark). • Power up the laser, and let it come to thermal equilibrium (approximately one hour). • Note the current temperature of the housing using the upper BNC connector. • Use the adjustment screw to set the target temperature approximately 2-3 °C above the current (ambient) housing temperature. The control temperature should be set such that the laboratory temperature never gets so warm as to have the heater current turn off (i.e. stops cycling). Normally, 2-3 °C is sufficient, but

	<p>this depends on the possible fluctuation of the laboratory temperature.</p> <p>IMPORTANT The control temperature should never exceed 50°C.</p>
Set Temperature Adjustment Screw	Use the Set Temperature Adjustment Screw to set the target temperature.